

SPECIFICATION

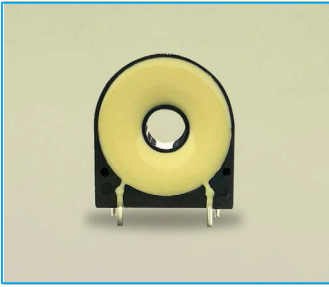

Commercial Grade Current Transformer

Model No ; **T-2P**

Type ; Standard Type

DIMENSION

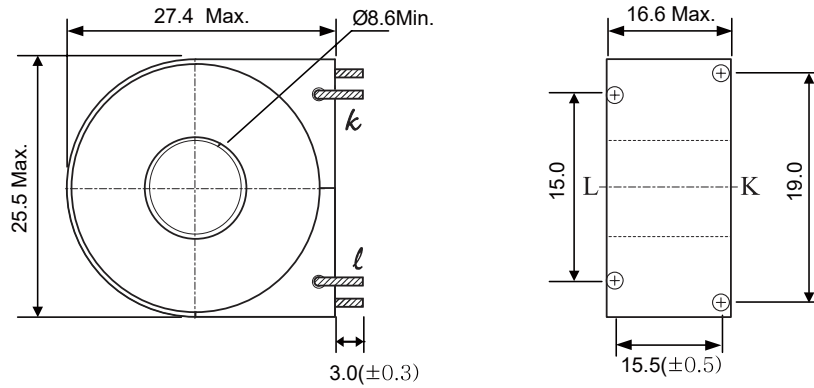

CHARACTERISTICS

At 50/60Hz, 100 Ω

ITEM	PROPERTY	CONDITION
CURRENT RATIO	1000:1	
RATED CURRENT	100A	
RATIO ERROR	$\pm 2.0\%$	1A~100A PRIMARY RATED'S 120%

TEST DIAGRAM

